

Write your name here

Surname

Other names

Pearson Edexcel
Level 1/Level 2 GCSE (9 - 1)

Centre Number

--	--	--	--	--	--

Candidate Number

--	--	--	--	--

Mathematics

Paper 2 (Calculator)

Higher Tier

Specimen Papers Set 1

Time: 1 hour 30 minutes

Paper Reference

1MA1/2H

You must have: Ruler graduated in centimetres and millimetres, protractor, pair of compasses, pen, HB pencil, eraser, calculator.

Total Marks

Instructions

- Use **black** ink or ball-point pen.
- **Fill in the boxes** at the top of this page with your name, centre number and candidate number.
- Answer **all** questions.
- Answer the questions in the spaces provided
– *there may be more space than you need.*
- **Calculators may be used.**
- If your calculator does not have a π button, take the value of π to be 3.142 unless the question instructs otherwise.
- Diagrams are **NOT** accurately drawn, unless otherwise indicated.
- You must **show all your working out.**



Information

- The total mark for this paper is 80
- The marks for **each** question are shown in brackets
– *use this as a guide as to how much time to spend on each question.*

Advice

- Read each question carefully before you start to answer it.
- Keep an eye on the time.
- Try to answer every question.
- Check your answers if you have time at the end.

Turn over ►

S49818A

©2015 Pearson Education Ltd.



PEARSON

Answer ALL questions.

Write your answers in the spaces provided.

You must write down all the stages in your working.

- 1** Make t the subject of the formula $w = 3t + 11$

(Total for Question 1 is 2 marks)

DO NOT WRITE IN THIS AREA

DO NOT WRITE IN THIS AREA

DO NOT WRITE IN THIS AREA

DO NOT WRITE IN THIS AREA

DO NOT WRITE IN THIS AREA

DO NOT WRITE IN THIS AREA

2 Three companies sell the same type of furniture.

The price of the furniture from Pooles of London is £1480

The price of the furniture from Jardins of Paris is €1980

The price of the furniture from Outways of New York is \$2250

The exchange rates are

$$£1 = €1.34$$

$$£1 = \$1.52$$

Which company sells this furniture at the lowest price?

You must show how you get your answer.

(Total for Question 2 is 3 marks)

- 3 The time-series graph gives some information about the number of pairs of shoes sold in a shoe shop in the first six months of 2014

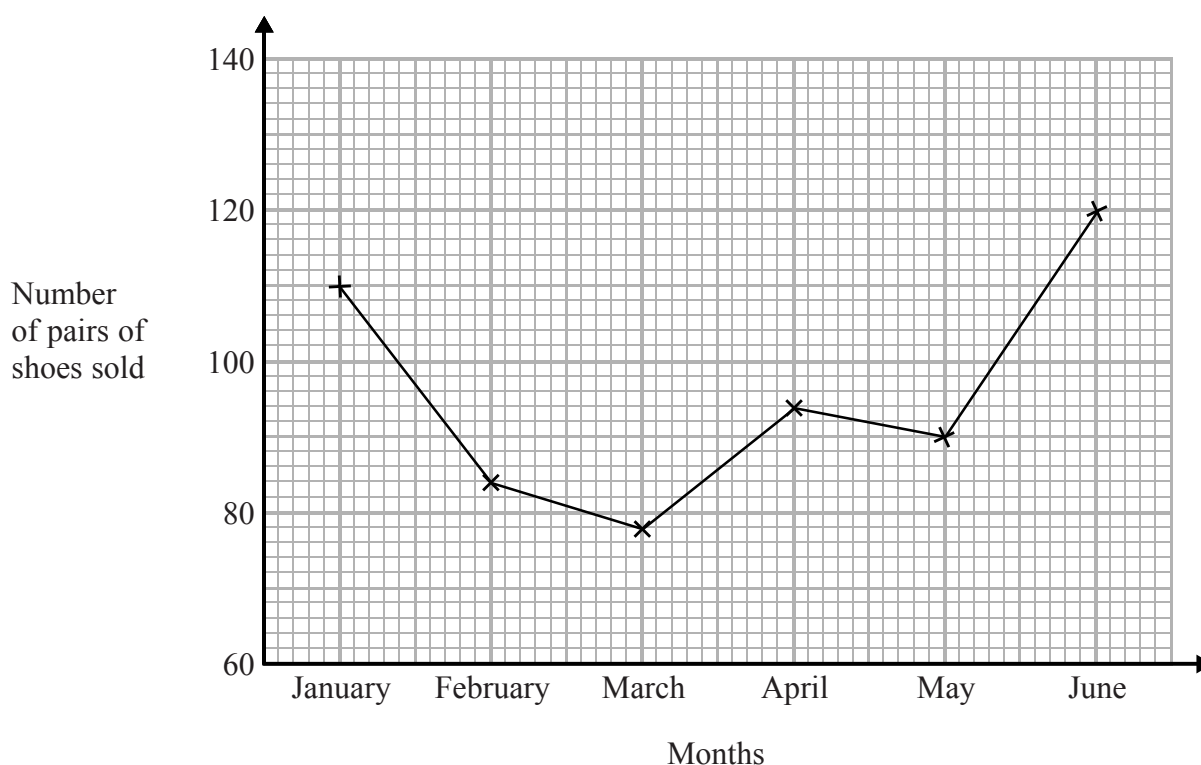

The sales target for the first six months of 2014 was to sell a mean of 96 pairs of shoes per month.

Did the shoe shop meet this sales target?
You must show how you get your answer.

(Total for Question 3 is 3 marks)

DO NOT WRITE IN THIS AREA

DO NOT WRITE IN THIS AREA

DO NOT WRITE IN THIS AREA

4 The grouped frequency table gives information about the heights of 30 students.

Height (h cm)	Frequency
$130 < h \leq 140$	1
$140 < h \leq 150$	7
$150 < h \leq 160$	8
$160 < h \leq 170$	10
$170 < h \leq 180$	4

(a) Write down the modal class interval.

.....
(1)

This incorrect frequency polygon has been drawn for the information in the table.

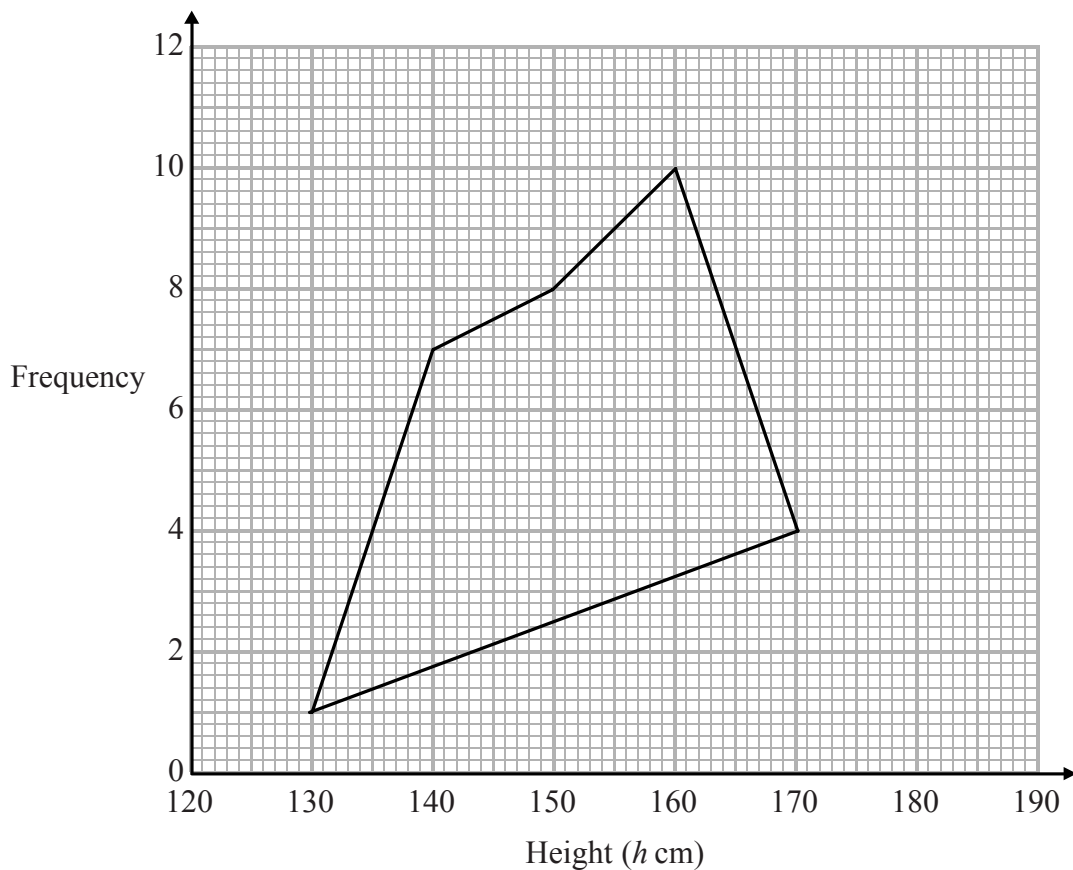

(b) Write down two things wrong with this incorrect frequency polygon.

1
2
(2)

(Total for Question 4 is 3 marks)

5 At 9 am, Bradley began a journey on his bicycle.

From 9 am to 9.36 am, he cycled at an average speed of 15 km/h.

From 9.36 am to 10.45 am, he cycled a further 8 km.

(a) Draw a travel graph to show Bradley's journey.

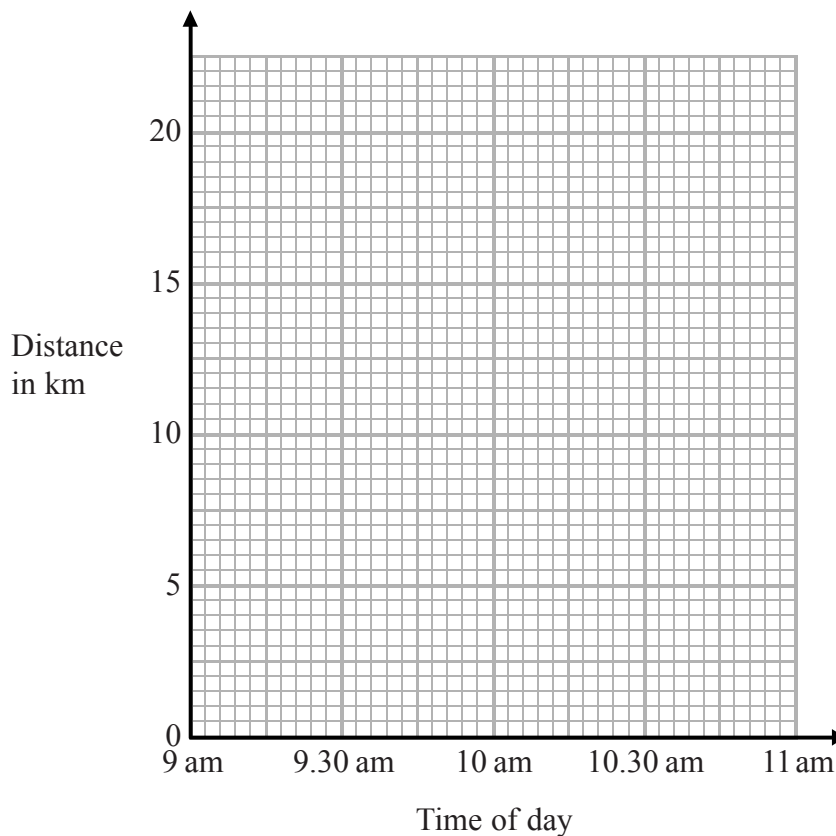

(3)

From 10.45 am to 11 am, Bradley cycled at an average speed of 18 km/h.

(b) Work out the distance Bradley cycled from 10.45 am to 11 am.

..... km

(2)

(Total for Question 5 is 5 marks)

DO NOT WRITE IN THIS AREA

- 6 Toby invested £7500 for 2 years in a savings account.
He was paid 4% per annum compound interest.

How much money did Toby have in his savings account at the end of 2 years?

£

(Total for Question 6 is 2 marks)

DO NOT WRITE IN THIS AREA

- 7 Becky has some marbles.
Chris has two times as many marbles as Becky.
Dan has seven more marbles than Chris.

They have a total of 57 marbles.

Dan says,

“If I give some marbles to Becky, each of us will have the same number of marbles.”

Is Dan correct?

You must show how you get your answer.

(Total for Question 7 is 3 marks)

DO NOT WRITE IN THIS AREA

8 Here is a diagram showing a rectangle, $ABCD$, and a circle.

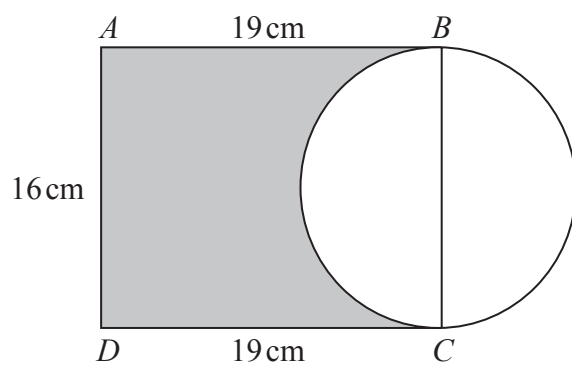

BC is a diameter of the circle.

Calculate the percentage of the area of the rectangle that is shaded.
Give your answer correct to 1 decimal place.

..... %

(Total for Question 8 is 4 marks)

DO NOT WRITE IN THIS AREA

DO NOT WRITE IN THIS AREA

DO NOT WRITE IN THIS AREA

9 The diagram shows the positions of three points, A , B and C , on a map.

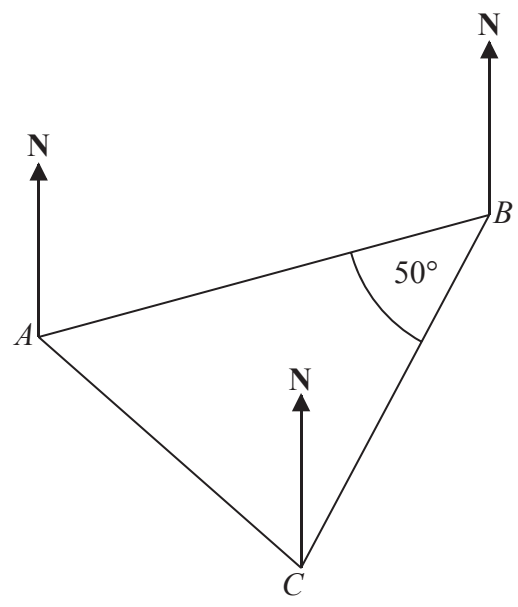

The bearing of B from A is 070°

Angle ABC is 50°

$AB = CB$

Work out the bearing of C from A .

.....
(Total for Question 9 is 3 marks)

10 The graph shows the depth, d cm, of water in a tank after t seconds.

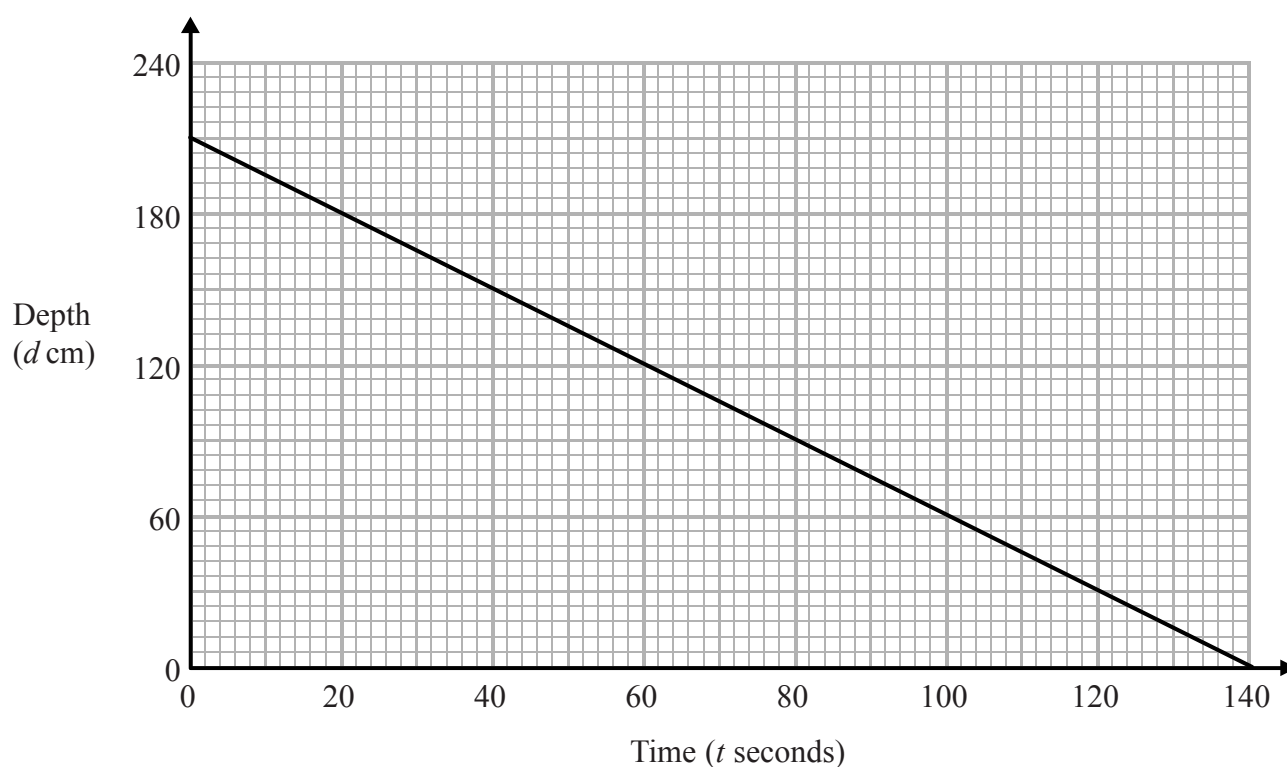

(a) Find the gradient of this graph.

.....
(2)

(b) Explain what this gradient represents.

.....
.....
(1)

(Total for Question 10 is 3 marks)

11 Finlay plays two tennis matches.

The probability that he will win a match and the probability that he will lose a match are shown in the probability tree diagram.

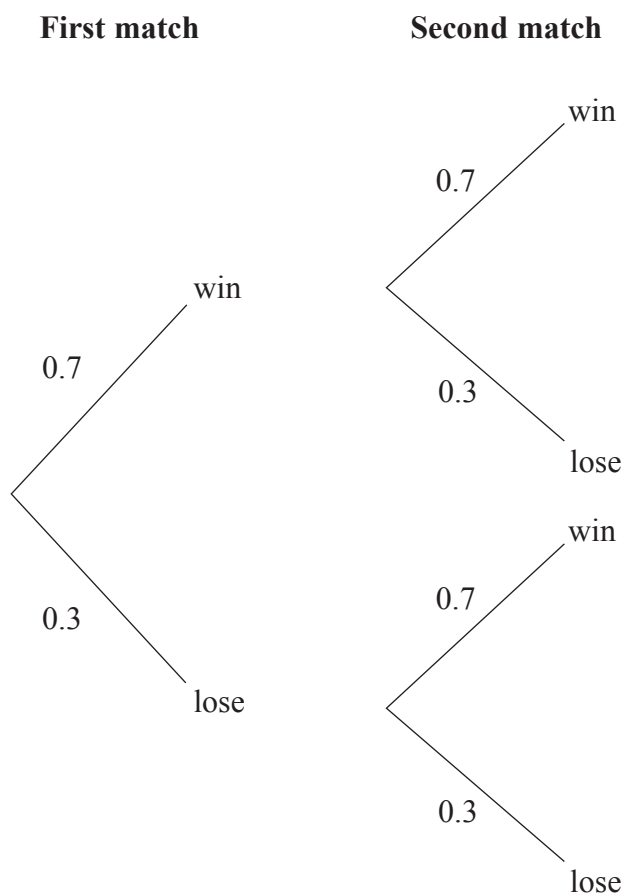

(a) Work out the probability that Finlay wins both matches.

.....
(2)

(b) Work out the probability that Finlay loses at least one match.

.....
(2)

(Total for Question 11 is 4 marks)

12 (a) Find the reciprocal of 2.5

.....
(1)

(b) Work out $\sqrt[3]{\frac{4.3 \times \tan 39^\circ}{23.4 - 6.06}}$

Give your answer correct to 3 significant figures.

.....
(2)

(Total for Question 12 is 3 marks)

13 Show that

$$(3x - 1)(x + 5)(4x - 3) = 12x^3 + 47x^2 - 62x + 15$$

for all values of x .

(Total of Question 13 is 3 marks)

DO NOT WRITE IN THIS AREA

DO NOT WRITE IN THIS AREA

DO NOT WRITE IN THIS AREA

14 ABC and ABD are two right-angled triangles.

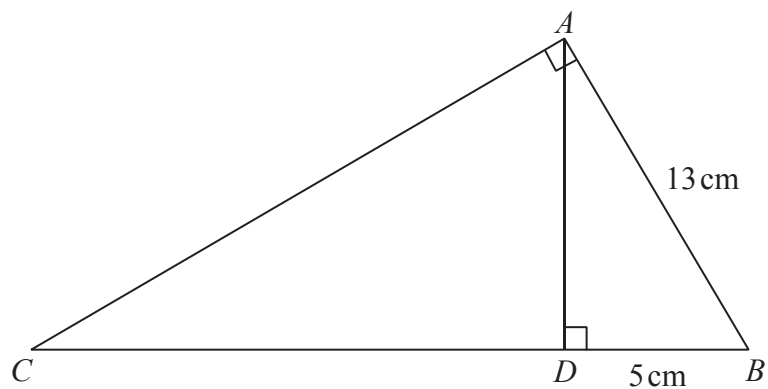

Angle $BAC = \text{angle } ADB = 90^\circ$

$AB = 13 \text{ cm}$

$DB = 5 \text{ cm}$

Work out the length of CB .

..... cm

(Total for Question 14 is 3 marks)

15 A pendulum of length L cm has time period T seconds.
 T is directly proportional to the square root of L .

The length of the pendulum is increased by 40%.

Work out the percentage increase in the time period.

.....%

(Total for Question 15 is 3 marks)

DO NOT WRITE IN THIS AREA

DO NOT WRITE IN THIS AREA

DO NOT WRITE IN THIS AREA

16 The histogram gives information about house prices in a village in 2015

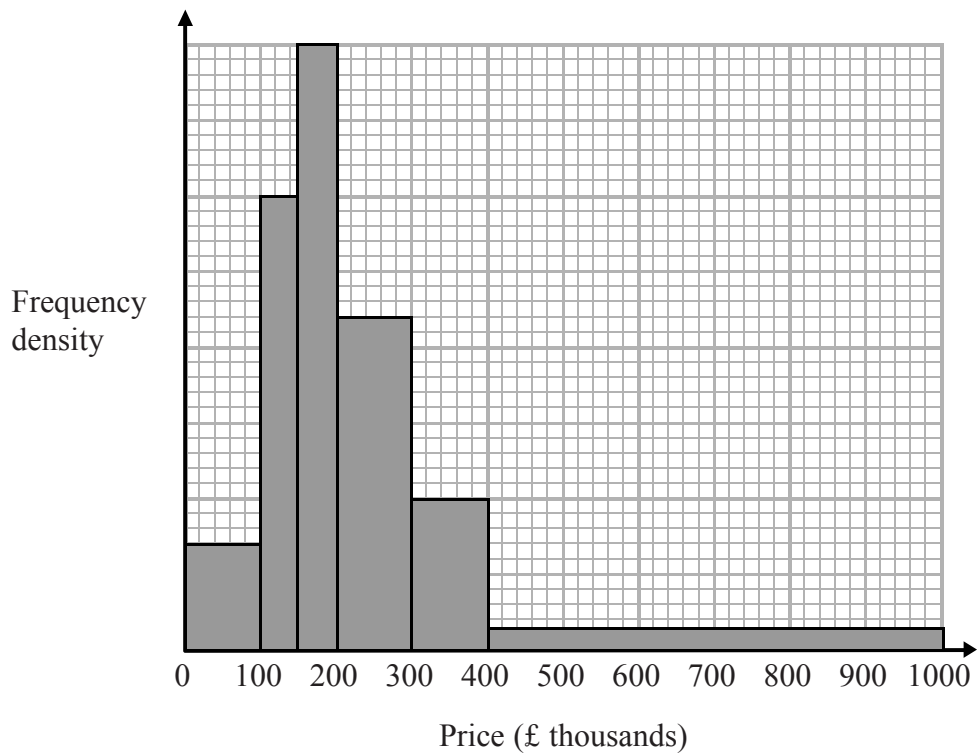

20 houses in the village have a price between £300 000 and £400 000

Work out the number of houses in the village with a price under £200 000

(Total for Question 16 is 3 marks)

17 Here are the first 5 terms of a quadratic sequence.

1 3 7 13 21

Find an expression, in terms of n , for the n th term of this quadratic sequence.

.....
(Total for Question 17 is 3 marks)

18 $f(x) = 3x^2 - 2x - 8$

Express $f(x + 2)$ in the form $ax^2 + bx$

.....
(Total for Question 18 is 3 marks)

DO NOT WRITE IN THIS AREA

DO NOT WRITE IN THIS AREA

DO NOT WRITE IN THIS AREA

DO NOT WRITE IN THIS AREA

DO NOT WRITE IN THIS AREA

DO NOT WRITE IN THIS AREA

19 Here is a right-angled triangle.

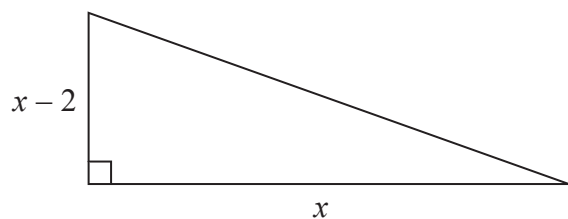

All measurements are in centimetres.
The area of the triangle is 2.5 cm^2 .

Find the perimeter of the triangle.
Give your answer correct to 3 significant figures.
You must show all of your working.

..... cm

(Total for Question 19 is 6 marks)

- 20 The graph shows information about the velocity, v m/s, of a parachutist t seconds after leaving a plane.

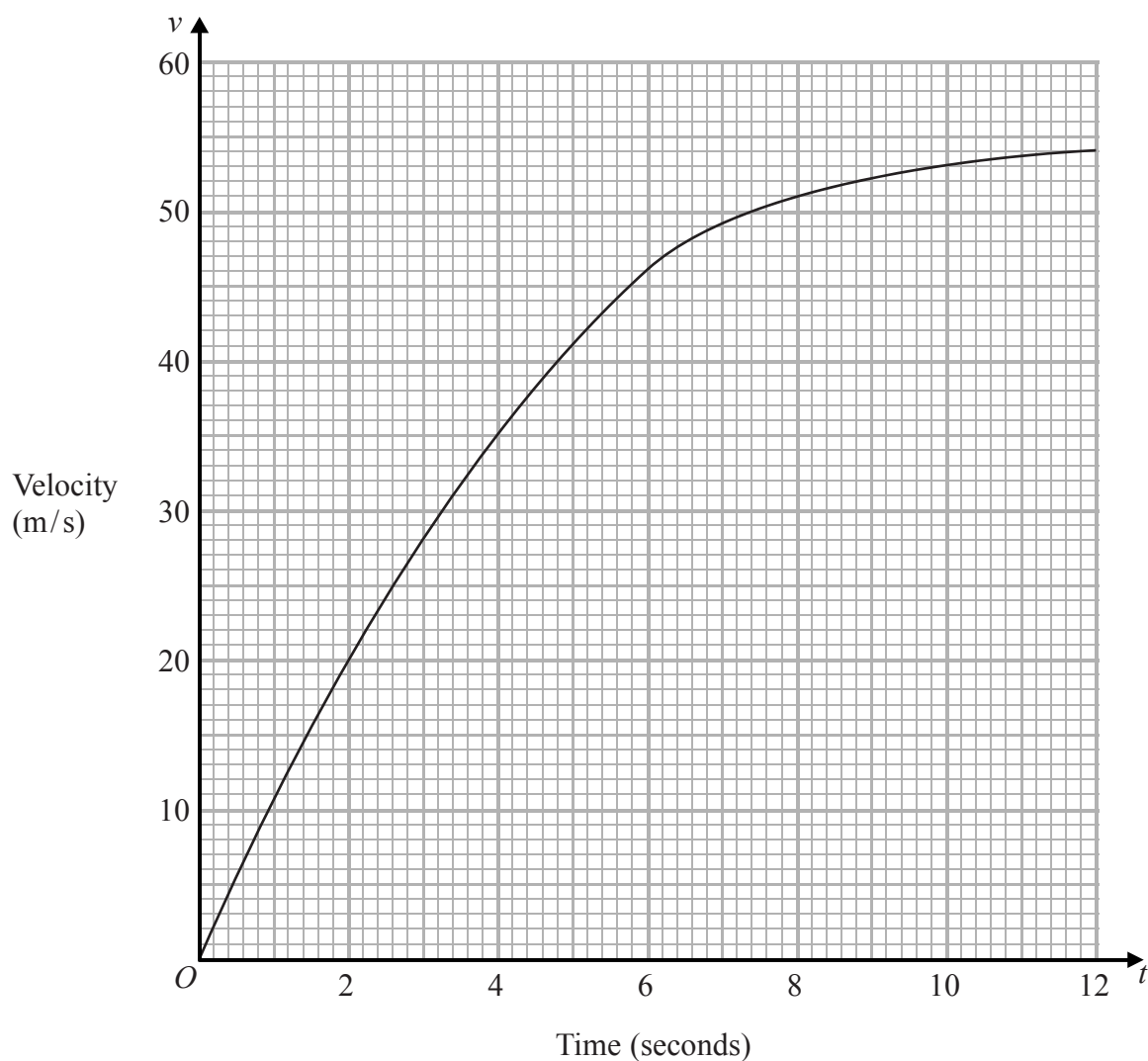

- (a) Work out an estimate for the acceleration of the parachutist at $t = 6$

..... m/s²
(2)

- (b) Work out an estimate for the distance fallen by the parachutist in the first 12 seconds after leaving the plane.
Use 3 strips of equal width.

..... m
(3)

(Total for Question 20 is 5 marks)

DO NOT WRITE IN THIS AREA

DO NOT WRITE IN THIS AREA

DO NOT WRITE IN THIS AREA

- 21 The number of bees in a beehive at the start of year n is P_n .
The number of bees in the beehive at the start of the following year is given by

$$P_{n+1} = 1.05(P_n - 250)$$

At the start of 2015 there were 9500 bees in the beehive.

How many bees will there be in the beehive at the start of 2018?

.....
(Total for Question 21 is 3 marks)

22 $D = \frac{x}{y}$

$x = 99.7$ correct to 1 decimal place.

$y = 67$ correct to 2 significant figures.

Work out an upper bound for D .

(Total for Question 22 is 3 marks)

DO NOT WRITE IN THIS AREA

DO NOT WRITE IN THIS AREA

DO NOT WRITE IN THIS AREA

DO NOT WRITE IN THIS AREA

DO NOT WRITE IN THIS AREA

DO NOT WRITE IN THIS AREA

23 Here is a circle, centre O , and the tangent to the circle at the point $P(4, 3)$ on the circle.

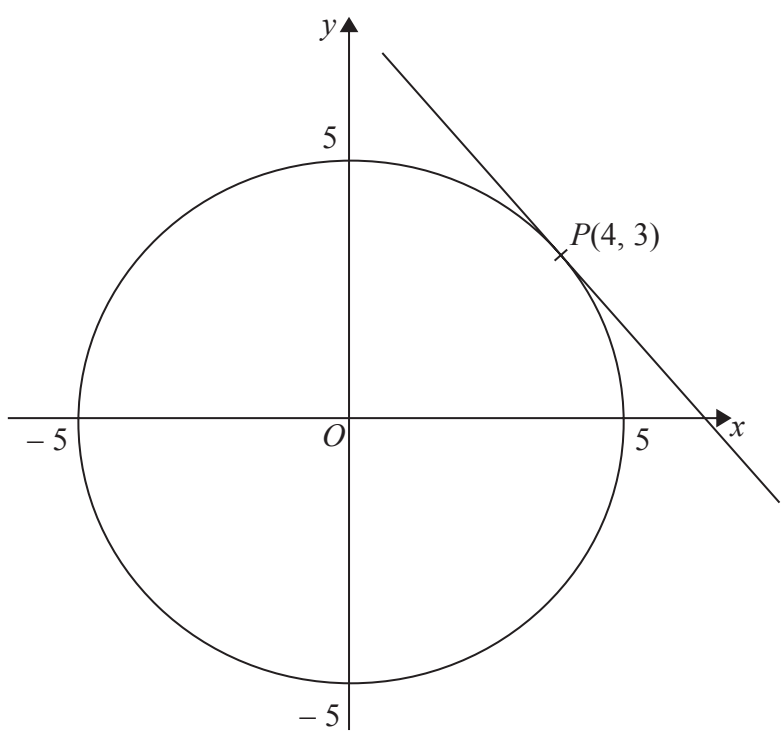

Find an equation of the tangent at the point P .

.....
(Total for Question 23 is 3 marks)

24 A , B and C are points on the circumference of a circle centre O .

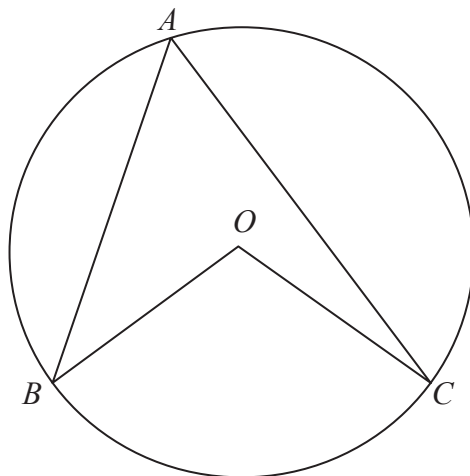

Prove that angle BOC is twice the size of angle BAC .

(Total for Question 24 is 4 marks)

TOTAL FOR PAPER IS 80 MARKS